



APAR - SALES OFFICE

05-090 Raszyn, ul. Gałczyńskiego 6

Tel. +48 22 101-27-31, +48 22 853-49-30

E-mail: automatyka@apar.pl

Website: www.apar.pl

USER INSTRUCTION



DATA RECORDER

AR200



Version 1.1.2
2012.10.23

Thank you for choosing our product.

*This instruction is intended to facilitate correct operation, safe use,
and taking full advantage of the recorder's functionalities.*

*Before you start the device, please read and understand this
instruction.*

*In the event of any additional questions, please contact our technical
adviser.*

CONTENTS

1. SAFETY PRINCIPLES	3
2. INSTALLATION GUIDELINES	3
3. GENERAL CHARACTERISTICS OF THE TWO-CHANNEL RECORDER	4
4. CONTENTS OF THE SET	5
5. TECHNICAL DATA	5
6. ENCLOSURE DIMENSIONS AND INSTALLATION DATA	6
7. DESCRIPTION OF TERMINAL STRIPS AND ELECTRICAL CONNECTIONS	6
8. BUTTON FUNCTIONS	7
9. CONNECTING TO A COMPUTER AND INSTALLATION OF DRIVERS	8
10. INSTALLATION OF SOFTWARE	8
11. DESCRIPTION OF DATA PRESENTATION ON THE LCD DISPLAY	9
11.1. STATUS BAR	9
11.2. LIST OF MEASUREMENTS (TEXT ONLY)	10
11.3. LIST OF MEASUREMENTS (TEXT AND GRAPHICS)	10
11.4. SINGLE MEASUREMENT (LARGE CHARACTERS)	11
11.5. SINGLE MEASUREMENT (DIAGRAM)	11
12. DELETING PARAMETERS AND OPERATIONS ON FILES (MAIN MENU)	11
12.1. RECORDING OPTIONS	13
12.2. MEMORY OPTIONS AND OPERATIONS ON FILES	14
12.3. CONFIGURATION OF MEASUREMENT INPUTS	15
12.4. CONFIGURATION OF ALARM OUTPUTS	16
12.5. DISPLAY OPTIONS	17
12.6. SERIAL COMMUNICATION OPTIONS RS485, USB, AND EtherNet	17
12.7. ACCESS OPTIONS	19
12.8. TIME AND DATE	19
12.9. INFORMATION ON THE DEVICE	19
13. OPERATION AND FUNCTIONS OF THE SD/MMC CARD AND THE USB MEMORY (PENDRIVE)	20

14. VIEWING RECORDED MEASUREMENTS AND EVENTS	20
15. MESSAGE AND ERROR SIGNALING	21
16. IMPORTANT COMMENTS PERTAINING TO OPERATION	21
17. RS485 COMMUNICATION INTERFACE (acc. to EIA RS-485)	22
18. MODBUS-RTU SERIAL TRANSMISSION PROTOCOL (SLAVE)	22
19. USER'S NOTES	24



Please pay particular attention to the text marked with this sign.

The manufacturer reserves the right to make changes to the design and the programming of the device without any deterioration of the technical parameters.

1. SAFETY PRINCIPLES



- before you start to use the device, become familiar with the present instructions;
- in order to avoid electrocution or damage to the device, its mechanical and electrical installation must be performed by qualified staff;
- before switching on the power supply, make sure that all cables and wires are properly connected;
- before making any modifications to the wire and cable connections, switch off the device's power supply;
- ensure proper operating conditions compliant with the technical specification of the device (chapter 5, power supply voltage, humidity, temperature).

2. INSTALLATION GUIDELINES



The device is designed so as to ensure an appropriate level of immunity to most interferences that may occur in industrial environments. In environments of unknown level of interferences, it is recommended to implement the following measures so as to prevent potential interference with the operation of the device:

- do not supply the device from the same lines as high-power equipment without using appropriate power line filters;
- use cable shields on power supply cables, sensor cables, and signal cables, whereby the earthing of the shield should be single-point and located as close to the device as possible;
- avoid running instrument (signal) cables in the direct vicinity of and parallel to power and supply cables;
- it is recommended to use twisted pair signal cables;
- in the case of sensing resistors in 3-wire connections, use identical wires;
- avoid proximity of remotely controlled devices, electromagnetic meters, high power loads, loads with phase or group power control, and other devices that cause high impulse disturbances;
- ground or zero metal rails on which rail-mounted devices are installed.

Make sure to remove the protective film from the LCD display before the first use of the device.

3. GENERAL CHARACTERISTICS OF THE TWO-CHANNEL RECORDER

- simultaneous recording of data from all available measurement inputs;
- 2 universal measurement inputs not galvanically isolated (thermoreistance, thermocouple, and analog);
- 2 alarm/control outputs with signaling of operating condition;
- data recording in a standard text file located in the internal memory of the recorder, on an SD/MMC card, or a USB memory in the FAT system;
- a serial USB interface, RS485 (isolated, MODBUS-RTU protocol) and Ethernet (10base-T, TCP/IP);
- a WWW server for work with any web browser (Opera, Firefox, etc.); the site contains information on the measurements, the status of the alarm outputs, the recording, the internal time, etc.;
- possibility to transfer archive data and configuration data on a SD card, a USB memory or using the USB port of a computer, or via Ethernet;
- a graphic LCD display, 128x32 dots, monochromatic, with background illumination (it enables assigning a different illumination brightness to each measurement channel);
- graphic, text, and mixed methods of presentation of the measured values;
- displaying measured data in a single- and double-channel mode;
- internal real time clock with a battery backup power supply;
- an integrated 24 V DC power supply supplying the field transducers;
- compensation of line resistance for resistance sensors (automatic or permanent);
- compensation of thermocouple cold tip temperature (automatic or permanent);
- enclosed free software enabling graphic or text presentation of recorded results and configuration of parameters
- programmable types of inputs, ranges of indications, alphanumeric description of measurement channels, recording, alarm, display, communication, and access options, and other configuration parameters;
- access to configuration parameters protected with a user password;
- parameter configuration methods:
 - from the IP65 film keypad located on the front panel of the device;
 - via the USB, the RS485, or the Ethernet and the ARSOFT-WZ1 free software (Windows 2000/XP/Vista/7);
 - from configuration files saved on the SD/MMC card or the USB memory;
- available protection of data against unauthorized copying and modification (checksum, demand for authorization of the SD card and the USB memory);
- possibility to differentiate archives from many recorders of the same type by assigning individual identification (ID) numbers;
- signaling of presence of SD/MMC and USB memory and operations on files;
- recording of data until the memory is full, full memory signalization;
- recorder firmware can be updated by the user;
- high accuracy and immunity to interferences;
- available accessories:
 - SD memory card (1 GB);
 - SD/MMC card reader;
 - USB memory (2 GB);

NOTE: 

Before you start working with the recorder, make sure to become familiar with this operating instruction and perform proper electrical and mechanical installation, as well as configuration of the parameters.

4. CONTENTS OF THE SET

- the recorder;
- a USB cable for connecting the device to a computer, 2 m long;
- a CD with the drivers and the software (Windows 2000/XP/Vista/7);
- operating instructions;
- a warranty card.

5. TECHNICAL DATA

Universal inputs (programmable):		Measurement ranges;	
Pt100 (RTD, 3- or 2-wire);		-200 ÷ 850 °C	
Ni100 (RTD, 3- or 2-wire)		-50 ÷ 170 °C	
– thermocouple J (Fe-CuNi)		-40 ÷ 800 °C	
– thermocouple K (NiCr-NiAl)		-40 ÷ 1,200 °C	
– thermocouple S (PtRh 10-Pt)		-40 ÷ 1,600 °C	
– thermocouple B (PtRh30PtRh6)		300 ÷ 1800 °C	
– thermocouple R (PtRh13-Pt)		-40 ÷ 1,600 °C	
– thermocouple T (Cu-CuNi)		-25 ÷ 350 °C	
– thermocouple E (NiCr-CuNi)		-25 ÷ 850 °C	
– thermocouple N (NiCrSi-NiSi)		-35 ÷ 1,300 °C	
– current ($R_{in} = 110 \Omega$)		0/4 ÷ 20 mA	
– voltage ($R_{in} = 250 \text{ k}\Omega$)		0 ÷ 10 V	
– voltage ($R_{in} > 2 \text{ M}\Omega$)		0 ÷ 60 mV	
– resistance (3- or 2-wire)		0 ÷ 850 Ω	
Number of measurement inputs		2, not galvanically separated	
Response time (10 ÷ 90%)		1 ÷ 10 s (programmable)	
Resistance of leads (RTD, Ω)		$R_d < 25 \Omega$ (for each line)	
Resistance input current (RTD, Ω)		approx. 550 μA	
Processing errors (at ambient temperature of 25 °C):			
- basic	- for RTD, mA, V, mV, Ω	0.1% of the measurement range ± 1 digit	
	- for thermocouples	0.2% of the measurement range ± 1 digit	
- additional for thermocouples		<2 °C (temperature of cold tips)	
- additional from ambient temperature changes		< 0.005% of the input range / °C	
Resolution of measured temperature		0.1 °C	
Communication interfaces	- USB (connection type A4)	- slave mode (device)	drivers compatible with Windows 2000/XP/Vista/7
		- master mode (host)	support of the USB memory (pendrive)
	- RS485 (MODBUS-RTU protocol, SLAVE, character format 8N1)		speed 2.4÷115,2 kbit/s, not galvanically separated (from the measurement input)
	- Ethernet (type 10base-T, RJ45 socket, option)		WWW server, TCP/IP protocols: DHCP, NetBIOS, ICMP, UDP, TCP, data transfer approx. 10 kB/s

Data recording interval		programmable 1 s to 8 hours (1)
Data memory (non-volatile, recording of up to 18 million measurements for 2 channels and 1 GB of memory):		
- internal		4 MB, FLASH, file system FAT12, recording of up to 72,000 measurements for 2 channels
- external SD/MMC card (connection with an ejector)		FAT16, FAT32, maximum size 2 GB, recommended size \leq 1GB and FAT16
- external USB memory (pendrive, connection type A4)		FAT16, FAT32, maximum size 4 GB recommended size \leq 1GB and FAT16
Real time clock (RTC) (backup supply: CR1220 lithium battery)		quartz, date, time takes into account leap years
Outputs (2 with shared contact)	- transmitter	5 A / 250 V- (for resistance loads), SPST
	- SSR (transistor, type NPN OC, optional)	24 V, internal resistance 850 Ω
Display		LCD, graphic, 128x32 dots, 73x19 mm background illumination with brightness adjustment
Power supply:	- 230 VAC	85-260 VAC/5VA
	- 24 VAC/DC (option)	20-50 VAC/ 5 VA, 22-72 VDC/ 5 W
Power supply of field transducers		24 VDC / 50 mA
Rated operating conditions		0-50 °C, <100% RH (no condensation)
Operating environment		air and neutral gases
Protection rating		IP65 from the front, IP20 from the side of the connections
Weight		approx. 215 g
Electromagnetic compatibility (EMC)		immunity: according to the PN-EN 61000-6-2:2002(U) standard (2)
		emissivity: according to the PN-EN 61000-6-4:2002(U) standard

(1) - minimum recording interval equal to 1 s is always possible for the internal memory. For the USB memory (pendrive) and the SD cards, the minimum guaranteed (even) interval of recording can be as short as several seconds and dependent on the size of the available memory, the file system, the archive file size, the maker (e.g. for SD cards with capacity \leq 256MB, FAT16 and USB memory with capacity \leq 1GB, FAT16, a 1 s recording interval is possible; tests were performed on SanDisk, GOODRAM, Kingston, and other memories), as well on the activity of the EtherNet interface.

(2) -in the case of industrial-level electromagnetic interferences, momentary deterioration of the quality of the displayed content of LCD screen is allowed; the quality must automatically return to the normal state after the interference is over; for levels specified in the PN-EN 61000-6-1:2002(U) standard, immunity fulfilled without reservations.

6. ENCLOSURE DIMENSIONS AND INSTALLATION DATA

Enclosure type	panel, Incabox XT L57
Material	self-extinguishing NORYL 94V-0, polycarbonate
Enclosure dimensions	96 x 48 x 79 mm
Panel window	92 x 46 mm
Fixing methods	grips on the side of the enclosure
Conductor cross-sections (separable connectors)	2.5 mm ² (supply and outputs), 1.5 mm ² (others)

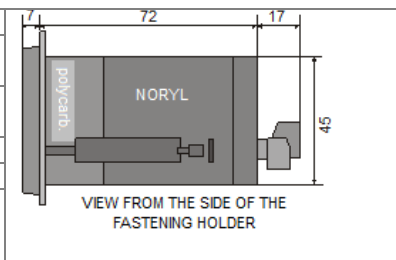

7. DESCRIPTION OF TERMINAL STRIPS AND ELECTRICAL CONNECTIONS

Terminals	Description
IN1-IN2-IN3	RTD (Pt100, Ni100) and resistance input (in 2- and 3-wire connection)
IN1-IN2	thermocouple input TC (J, K, S, B, R, T, E, N) and voltage input 0÷60 mV
IN1-GND	current input 0/4÷20 mA
IN2-GND	voltage input 0÷10 V
1-2	RS485 serial interface (MODBUS-RTU transmission protocol)
3	output +24 V (in relation to the GND) of the integrated power supply of field transducers
11÷13	outputs of transmitters P1, P2 or SSR1, SSR2
14-15	power supply input 230 VAC or 24 VAC/DC
ETHERNET	serial Ethernet interface (type 100base-T, RJ45 socket, TCP/IP protocols)
USB	serial USB interface (programmable operation mode: device or host, chapter 12.6)
SD CARD	SD/MMC memory card slot (maximum capacity 2 GB)

a) numbering of connections and method of connecting sensors and measurement signals

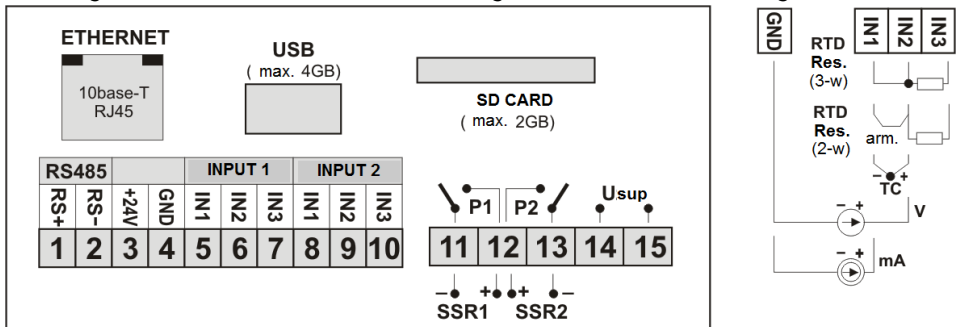

b) connection of a 2- and 3-wire transducer (I_{out} - output current, U_{out} - output voltage)

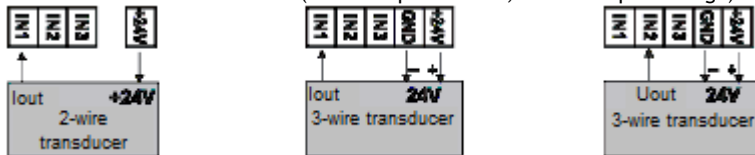



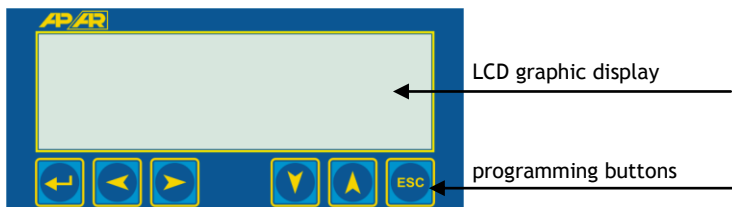

8. BUTTON FUNCTIONS





View of the front panel



a) button functions in the list or single measurement display mode (chapter 11)

Button	Description [and marking in the contents of the instructions]
	[SET]: input in the parameter configuration and file operation menu (after holding time longer than 1 s; if <i>Password Protection</i> in <i>Access Options</i> is <i>On</i> , enter the password; see chapter 12.6)
 	[DOWN] or [UP]: a change in the method of presentation of measured data (list of measurements or single measurement, chapter 11)
 	[LEFT] or [RIGHT]: a change of the displayed channel in the single measurement presentation mode

b) functions of the buttons in the parameter configuration and file operations mode (*Main Menu*, chapter 12)

Button	Description
SET 	- selects the marked item in the menu (entering a lower menu level or edition of a parameter) - approves the edited parameter value (it is saved in the non-volatile FLASH memory takes place after leaving the Main Menu or the USB is disconnected from the computer)
 	[DOWN] or [UP]: - moves to the next or previous item in the menu - changes the value of the edited parameter (also [LEFT] or [RIGHT])
 [ESC]	- returns to the previous menu (higher level) - cancels the changes to the edited parameter - exits the Main Menu and returns to the measurement presentation mode

9. CONNECTING TO A COMPUTER AND INSTALLATION OF DRIVERS

Before connecting the cable to the USB port of a computer, make sure that the *USB operating mode* parameter is set to *Accessible for a computer* (chapter 12.6). After the first connection, the Windows (2000/XP/Vista/7) system detects the recorder named “*APAR USB DEVICE*” and demands installation of drivers. In the find new device wizard, manually indicate the location of the drivers on a CD-ROM, the *DRIVERS* catalog).

In the Windows XP system, the installation procedure is the following:

1. Choose the option “*No, not this time*” and press the “*Continue*” button.
2. Choose “*Install from a list or a specific location (advanced)*” and press the “*Continue*” button.
3. Select “*Find the best driver in those locations*” and the selection field “*Include this location in the search;*” press the “*View*” button, in the dialog box select the *DRIVERS* folder, press the “*Continue*” button, when the warning “*Installing a device*” appears, press “*Continue anyway.*”
4. The virtual COM port “*CDC USB to UART*” is installed; press “*Finish.*”
5. The system then detects and installs the “*Mass storage device*” -> “*ATMEL MASS STORAGE USB Device*” -> “*Disk drive.*”

After the installation is completed, the recorded is listed in the system as a virtual COMx port (x-port number: 1, 2, ...) and two exchangeable disks: internal memory 4 MB with the AR200 label and SD/MMC memory (available after the card is put in the “*SD/MMC CARD*” slot). In the internal memory two configuration text files are shown: *AR200.2.cfg* and *AR200_nazwy.txt* (chapter 12).

NOTE: 

Do not disconnect the device from the computer before the installation of drives is completed and whenever the device is connected again to the USB port when disks are being detected (when the [R/W] icon is shown; see chapter 11.1).

10. INSTALLATION OF SOFTWARE

In the "SOFTWARE" folder of the CD-ROM that is provided with the device there is a free software installation set for the recorder. The set contains the following applications:

- **ARSOFT-WZ1** - display of current measurement data, as well as the date and the time,
- configuration of the real time clock (RTC) and other parameters, such as types and names of measurement inputs, ranges of indications, recording, alarm, display, communication, and access options etc. (chapter 12),
- creation on the disk of a "cfg" file with the current configuration of the parameters for future use (copying of configuration),
- the program requires communication with the recorder via the USB, RS485 or Ethernet port (**on-line configuration**),
- **ARSOFT-WZ3** - graphic or text presentation of the recorded results with printing option; the input data is collected at one time from a text file with an "csv" extension, created in the recorder in the internal memory, in the USB memory, or on the SD/MMC card (chapter 14); the data can also be collected via the Ethernet network.
- **ARSOFT-WZ4** - creation on the disk of a configuration file with a "cfg" extension that enables programming the recorder using the USB interface or the SD/MMC card; this is a parameter configuration without the possibility to set the RTC and ID parameters. The program does not communicate with the recorder (**off-line configuration**).

The latest versions of the aforementioned programs are also available at the website (www.apar.pl, Download tab). The detailed descriptions of the aforementioned applications can be found in the installation folders.

11. DESCRIPTION OF DATA PRESENTATION ON THE LCD DISPLAY

The recorder enables presentation of the measurement data in a single- and double-channel mode in accordance with the following diagram:

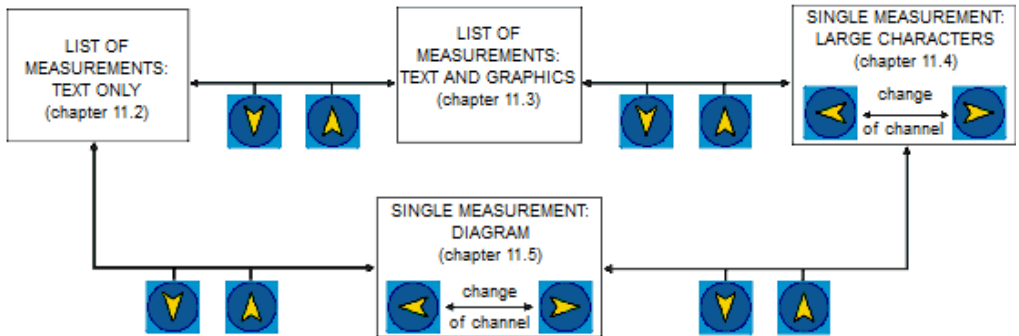

Fig. 11. Block diagram of the available measurement data presentation modes

11.1. STATUS BAR

The status bar can be seen in the upper part of the display in most measurement presentation modes. The meaning of the individual graphic elements is described below.

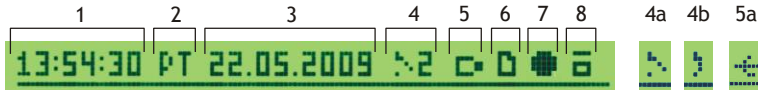

Figure 11.1. The status bar

Element	Description
1, 2, 3	time, day of the week, and date (dd.mm.yyyy) on the real time clock (RTC, chapter 12.8)
4, 4a, 4b	status of alarm outputs, from the 1st to the 2nd (chapter 12.4); 4a - the output is switched off (the alarm is inactive); 4b - the output is switched off (alternately with the number of the input channel that activates the alarm);
5, 5a	signaling of the presence of the USB memory (5) or connection to the USB port of a computer (5a); (chapter 12.6)
6	signaling of the presence of the SD/MMC card in the recorder;
7	signaling of ongoing recording in the internal memory, on the SD/MMC card, or in the USB memory;
8	signaling of writing to or reading from the memory (in the text, it is marked as the [R/W] icon).

11.2. LIST OF MEASUREMENTS (TEXT ONLY)



Figure 11.2. Appearance of the measurement list screen in the *TEXT ONLY* mode

Element	Description
1	status bar (chapter 11.1)
2	measurement channel number
3	channel name (up to 15 characters per channel, taken from the <i>AR200_nazwy.txt</i> file, chapter 12.3)
4	measured value with signaling of exceeded measurement range (chapters 12.3 and 15)
5	channel unit (up to 4 characters per channel, taken from the <i>AR200_nazwy.txt</i> file, chapter 12.3)

11.3. LIST OF MEASUREMENTS (TEXT AND GRAPHICS)

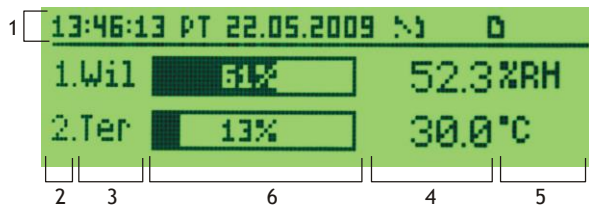

Figure 11.3. Appearance of the measurement list screen in the *TEXT AND GRAPHICS* mode

Element	Description
1	status bar (chapter 11.1)
2	measurement channel number
3	channel name (up to 3 characters per channel, taken from the <i>AR200_nazwy.txt</i> file, chapter 12.3)
4	measured value with signaling of exceeded measurement range (chapters 12.3 and 15)
5	channel unit (up to 4 characters per channel, taken from the <i>AR200_nazwy.txt</i> file, chapter 12.3)
6	graphic presentation of the measurement (bar graph) in the range set by the parameters <i>Bottom of the indication range</i> and <i>Top of the indication range</i> (chapter 12.3)

11.4. SINGLE MEASUREMENT (LARGE CHARACTERS)

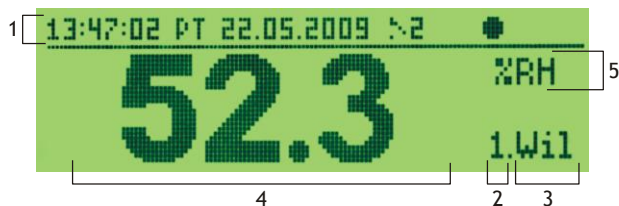

Figure 11.4. Appearance of a single screen in the *LARGE CHARACTERS* mode

Element	Description
1	status bar (chapter 11.1)
2	measurement channel number (changed using the [LEFT] or [RIGHT] button)
3	channel name (up to 3 characters per channel, taken from the <i>AR200_nazwy.txt</i> file, chapter 12.3)
4	measured value with signaling of exceeded measurement range (chapters 12.3 and 15)
5	channel unit (up to 4 characters per channel, taken from the <i>AR200_nazwy.txt</i> file, chapter 12.3)

11.5. SINGLE MEASUREMENT (DIAGRAM)

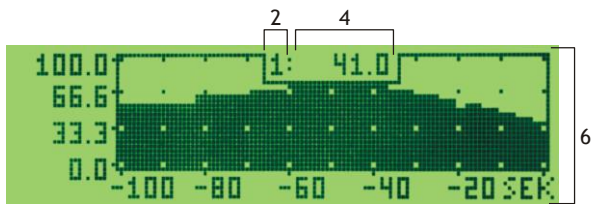

Fig. 11.6. Appearance of a single screen in the DIAGRAM mode

Element	Description
2	measurement channel number (changed using the [LEFT] or [RIGHT] button)
4	measured value with signaling of exceeded measurement range (chapters 12.3 and 15)
6	graphic presentation of the measurement (diagram) in the range set by the parameters <i>Bottom of the indication range</i> and <i>Top of the indication range</i> (chapter 12.3, 12.5)

12. DELETING PARAMETERS AND OPERATIONS ON FILES (MAIN MENU)

All the configuration parameters and names and measurement units of the recorder channels are stored in the non-volatile FLASH internal memory in two text files: *AR200.cfg* (parameters) and *AR200_nazwy.txt* (names and units - changes can be implemented only using a computer in the ARSOFT-WZ1 software via the USB port or the Ethernet, as well as in any text editor, e.g. Windows Notebook). When the device is switched on for the first time, an error message may be shown in the display due to the lack of a sensor or the fact that the sensor that is connected is not one that is factory-programmed. In such an event, the proper sensor or analog signal must be connected and the configuration must be programmed.

The parameter configuration can be performed using one of the following three methods (**do not use them at the same time**):

1. From the IP65 film keypad located on the front panel of the device:

- from the measurement list or single measurement display mode, go to the **Main Menu** (press and hold the [SET] button for more than 1 s). If **Password Protection in Access Options** is **On**, enter the password - the default value is 1111; see chapter 12.7.



Fig. 12. Appearance of the password screen and the **Main Menu**

- use buttons [UP] or [DOWN] to select an appropriate sub-menu or parameter to be changed/viewed;
- use the [SET] button to select the highlighted item in the menu (this also caused the parameter to be edited);
- use buttons [UP] or [DOWN] to change the value of the edited parameter;
- approve the changed value of the parameter by pressing the [SET] button or cancel it by pressing the [ESC] button;
- in the parameter edition mode, the symbols of the inactive buttons are displayed in the bottom part of the screen.

2. Use the USB or RS485 port, or the Ethernet and the ARSOFT-WZ1 software (**on-line configuration**):
 - connect the recorder to a computer port and to start the ARSOFT-WZ1 application
 - after the connection has been established, the current measured values and the internal time and date of the recorder are displayed in the application window
 - setting and viewing of the device parameters is possible in the parameter configuration window
 - new parameter values must be approved with the **Approve changes** button
 - the software enables synchronization of the time and the date with the computer
 - the current configuration can be saved in a file or set using values read from a file
 - the recorder updates the configuration files and the displayed names after it is disconnected from the computer's USB port
 - online configuration via the USB port is possible only when the **USB operation mode** parameter is set as **Available for computer** (chapter 12.6).

NOTE:



- before disconnecting the device from a computer, press the **Disconnect device** button
- in the event of no response:
 - in the **Program options** check the configuration of the port and the **MODBUS Address of the device**
 - make sure that the serial port drivers have been installed correctly
 - disconnect for a few seconds and then reconnect the recorder to the USB port
 - restart the computer

3. From the configuration file created in the ARSOFT-WZ4 software (**off-line configuration**):
 - start the ARSOFT-WZ4 application and, in the **Device** field, select the device name (AR200)
 - set the required parameters (except for the **RTC** and the identification number **ID**)
 - a current configuration can also be prepared by modifying the values read from the existing files
 - save the created configuration in an **AR200.cfg** or **AR200_nazwy.txt** file and save it to a SD/MMC card or a USB memory
 - install the SD card or the USB memory in the appropriate slot and then, in the **Memory and file options** of the recorder, upload the relevant configuration files (**Parameters** from **AR200.2.cfg** or **Names** from **AR200_nazwy.txt**), see chapter 12.2
 - after the configuration has been completed, the memory can be disconnected from the socket

In the event of indications different than the actual value of the input signal, the zero and the sensitivity of a sensor can be adjusted in the **Input configuration** menu: the **Zero calibration** and the **Inclination calibration** (sensitivity) parameters, chapter 12.3.

The default settings can be restored in the **Memory and file options** (chapter 12.2).

As an alternative, a file with default configuration can be used in the ARSOFT-WZ1 software.

NOTE:



Do not shut down the power supply during the configuration performed using the keypad or on-line (via the computer's USB port) because the changed parameter values are stored in the non-volatile FLASH memory after the user exits the **Main Menu** (by pressing the **[ESC]** button) or disconnects the device from the USB port.

12.1. RECORDING OPTIONS

Data is archived in a text file with a csv extension in the internal memory, on the SD/MMC card, or in the USB memory; a detailed description of the storage format is given in chapter 14. Data is recorded until the memory is full and then the recording is stopped and the **"Memory full. Saving rejected"** message is displayed repeatedly. The recording must then be stopped (the **Recording type** must be set to the **OFF**

value, Table 12.1), the archive files must be copied for further analysis, and space must be freed up in the memory for future recordings. The selection of the memory for recording and the copying and deleting of existing csv files are accessible in the **Main Menu -> Memory and file options**; a detailed description of operations performed on files is given in chapter 12.2.

Table 12.1. Configuration parameters in the **Recording options** menu

Parameter	Range of variability of the parameter and description		Default settings
Data recording interval (1)	1 s to 8 h (note (1) in the technical data, chapter 5)		1 minute
Recording type (2)	<i>Off</i>	recording switched off permanently	<i>Limited by time</i>
	<i>Continuous</i>	recording switched on permanently	
	<i>Limited by time</i>	recording is active within the range of the time defined by the <i>Start</i> and <i>End parameters of time limit</i>	
	<i>Above the permission threshold</i>	recording is active when the measured value of the channel defined by the <i>Channel selection</i> is larger than the value of the <i>Permission threshold value</i> parameter	
	<i>Below the permission threshold</i>	recording is active when the measured value of the channel defined by the <i>Channel selection</i> is smaller than the value of the <i>Permission threshold value</i> parameter	
Start of time limit	date: 01.06.2008 ÷ 31.12.2099 , time: 00:00:00 ÷ 23:59:59 , the parameter is active when the Recording mode is Time-limited		2008.06.01 00:00:00
End of time limit	date: 01.06.2008 ÷ 31.12.2099 , time: 00:00:00 ÷ 23:59:59 , the parameter is active when the Recording mode is Time-limited		2008.06.01 00:00:00
Selection of permit channel	Measurement channel 1 - Measurement channel 2 the parameter is active when Type of recording = Above or Below the permission threshold		<i>Measurement channel 1</i>
Permission threshold value	-199.9 ÷ 1999.9 °C or -9999 ÷ 19999 units (3) the parameter is active when Type of recording = Above or Below the permission threshold		100.0 °C

Notes: (1) - the recording interval is counted from the moment the device is disconnected from the USB port

(2) - the device does not record data in a file when it is connected to the computer's USB port

(3) - applies to analog inputs (mA, V, mV, Ω)

12.2. MEMORY OPTIONS AND OPERATIONS ON FILES

Table 12.2. Configuration parameters and file operations in the **Memory and file options** menu

Parameter or file operation	Description of the available file operations and parameters		Company settings
Memory size	<i>Internal memory</i>		
	<i>SD card</i>		
	<i>USB memory</i>		
Send archive (1)	<i>Cancel</i>	return to the previous menu (higher level)	

Figure 12.2. Appearance of the memory size screen (recording interval 3 s for 2 channels)

The field "Enough for:" takes into account the **Data recording interval** (chapter 12.1) and the number of active measurement inputs (12.3)

	To the SD card	copy the archive (files with the csv extension) from the internal memory to the SD/MMC card	
	To the USB memory	copy the archive (files with the csv extension) from the internal memory to the USB memory (Operating mode of the USB = USB memory support , chapter 12.6)	
	From the SD card to the USB	copy the archive (files with the csv extension) from the SD/MMC card to the USB memory (Operating mode of the USB = USB memory support , chapter 12.6)	
Delete the archive	Cancel	return to the previous menu (higher level)	
	Internal memory	delete the archive (files with the csv extension) from the internal memory	
	SD card	delete the archive (files with the csv extension) on the SD/MMC card	
	USB memory	delete the archive (files with the csv extension) from the USB memory	
Memory to be saved (2) (chapter 12.6)	Internal memory only	archive files are created only in the internal memory	Automatic selection
	Only SD or internal	archive files are created only on the SD/MMC card or in the internal memory when there is no card	
	Automatic selection	archive files are created in the order of appearance: in the USB memory, on the SD/MMC card, or in the internal memory	
Identification number (ID)	0÷9999	an individual device number entered into the initial records in the archive file (csv) in order to distinguish archives from different recorders of the same type	0
Send the configuration	Cancel	return to the previous menu (higher level)	
	To the SD card	copy the current settings (<i>AR200.2.cfg</i> and <i>AR200_nazwy.txt</i>) to the SD card	
	To the USB memory	copy the current settings (<i>AR200.2.cfg</i> and <i>AR200_nazwy.txt</i>) to the USB memory (Operating mode of the USB = USB memory support , chapter 12.6)	
Configure from the SD	Cancel	return to the previous menu (higher level)	
	Parameters	copy the configuration parameters (<i>AR200.2.cfg</i>) from the SD card	
	Names	copy the channel names and units (<i>AR200_nazwy.txt</i>) from the SD card	
Configure from the USB (chapter 12.6)	Cancel	return to the previous menu (higher level)	
	Parameters	copy the configuration parameters (<i>AR200.2.cfg</i>) from the USB memory	
	Names	copy the channel names and units (<i>AR200_nazwy.txt</i>) from the USB memory	
Restore default	Cancel	return to the previous menu (higher level)	
	Parameters	set the default configuration parameters (<i>AR200.2.cfg</i>) in the recorder	
	Names	set the default channel names (<i>AR200_nazwy.txt</i>) in the recorder	
Format the memory (3)	Cancel	return to the previous menu (higher level)	
	Internal memory	format the internal memory in the FAT12 system, preserving the current settings (parameters in the <i>AR200.2.cfg</i> file and names in <i>AR200_nazwy.txt</i> file)	
	SD card	format the SD/MMC card in the FAT16 or FAT32 system (when the capacity > 2 GB)	
	USB memory	format the USB memory in the FAT16 or FAT32 system (when the capacity > 2 GB)	

Notes: (1) - in the case of a 4 MB archive file, the copying time is equal to approx. 2 min. and in the case of a 250 MB file - approx. 30 min.

(2) - it is possible to demand authorization of the SD card and the USB memory (chapter 12.7, parameter **SD and USB authorization**)

(3) - formatting deletes all data from the memory (with the exception of configuration files in the internal memory); this is recommended in the event of problems with accessing data

Until the file operations or the formatting of memory is completed, the recording and the EtherNet transfer are disabled.

NOTE: 

During file operations or formatting of memory, do not shut down the power supply, do not connect the device to a computer's USB port, and do not take out exchangeable memory, as this may cause loss of recorded data and the current configuration (parameters and names).

12.3. CONFIGURATION OF MEASUREMENT INPUTS

Table 12.3. Configuration parameters in the *Input configuration* menu for the selected measurement channel

Parameter	Range of variability of the parameter and description		Company settings
<i>Name and unit</i>	Edition of names (max. length 15 characters per channel) and units (4 characters) is possible on a computer (via the USB port or the Ethernet and the ARSOFT-WZ1 software, or by copying of the configuration - chapter 12.2). The format of a section for a single channel in the <i>AR200_nazwy.txt</i> file is the following: <i>[Chan1]</i> <i>name=Measurement of channel 1</i> <i>unit=*C</i>		<i>Measurement of channel i</i> (for i=1-2)
			°C
<i>Type of input</i>	<i>Off</i>	the measurement channel is absent in the presentation and the recording	<i>Pt100</i>
	<i>Pt100</i>	thermoresistance sensor (RTD) Pt100 (-200 ÷ 850 °C)	
	<i>Ni100</i>	thermoresistance sensor (RTD) Ni100 (-50 ÷ 170 °C)	
	<i>J (Fe-CuNi)</i>	thermoelectric sensor (thermocouple) type J (-40 to 800 °C)	
	<i>K (NiCr-NiAl)</i>	thermoelectric sensor (thermocouple) type K (-40 to 1,200 °C)	
	<i>S (PtRh 10-Pt)</i>	thermoelectric sensor (thermocouple) type S (-40 to 1,600 °C)	
	<i>B (PtRh30PtRh6)</i>	thermoelectric sensor (thermocouple) type B (-300 to 1,800 °C)	
	<i>R (PtRh13-Pt)</i>	thermoelectric sensor (thermocouple) type R (-40 to 1,600 °C)	
	<i>T (Cu-CuNi)</i>	thermoelectric sensor (thermocouple) type T (-25 to 350 °C)	
	<i>E (NiCr-CuNi)</i>	thermoelectric sensor (thermocouple) type E (-25 to 820 °C)	
	<i>N (NiCrSi-NiSi)</i>	thermoelectric sensor (thermocouple) type N (-35 to 1,300 °C)	
	<i>4..20 mA</i>	current signal 4...20 mA	
	<i>0..20 mA</i>	current signal 0...20 mA	
	<i>0..10 V</i>	voltage signal 0...10 V	
<i>0..60 mV</i>	voltage signal 0...60 mV		
<i>0..850 Ω</i>	resistance signal 0...850 Ω		
<i>Line resistance (1)</i>	<i>0.00÷50.00</i>	total resistance of leads for 2-wire RTD sensors and 850	<i>0.00 Ω</i>

	Ω	Ω	
Temperature of cold thermocouple tips	Auto 0.1 ÷ 60.0 °C	automatic or constant compensation of temperature of the cold junction of thermocouples	<i>Auto</i>
Position of the point/resolution	None	no point (2) or 1°C for temperature	<i>Position 1</i> <i>(0.0/0.1°C)</i>
	Position 1	0.0 (2) or resolution 0.1 °C for temperature	
	Position 2	0.00 (2)	
	Position 3	0.000 (2)	
Bottom of the indication range	-199.9 ÷ 1,999.9 °C or -9,999 ÷ 19,999 units (2) - indication for 0 mA, 4 mA, 0 V, 0 mV, 0 Ω - start of the input scale		-100.0 °C
Top of the indication range	-199.9 ÷ 1999.9 °C or -9999 ÷ 19999 units (2) - indication form 20 mA, 10 V, 60 mV, 850 Ω - end of the input scale		800.0 °C
Filtration (3)	1 ÷ 20	digital filtration of measurements (response time)	1
Calibration of the zero	zero offset: -50.0 ÷ 50.0 °C or -500 ÷ 500 units (2)		0.0 °C
Calibration of the inclination	sensitivity (gain): 85.0 ÷ 115.0 %		100.0 %
Assigning the alarm output	Alarm output 1 ÷ Alarm output 4 or None - selection of an alarm output activated by the measurement of the current channel, chapter 12.4		<i>Alarm out. i</i> <i>(for i=1-2)</i>
Background brightness	0 ÷ 100 % , change by 5%		100%

Notes: (1) - in the case of 3-wire sensors, there is automatic line resistance compensation and the *Line resistance* parameter must be equal to **0.00 Ω**

(2) - applies to analog inputs (mA, V, mV, Ω)

(3) - in the case of *FILtration*=1 the response time is equal to 1 s, in the case of *FILtration*=20 it is equal to at least 10 s. Higher degree of filtration means a "smoother" measured value and a longer response time, which is recommended in the case turbulent measurements (e.g. water temperature in the boiler).

12.4. CONFIGURATION OF ALARM OUTPUTS

Table 12.4. Configuration parameters in the *Alarm configuration* menu for the selected alarm output

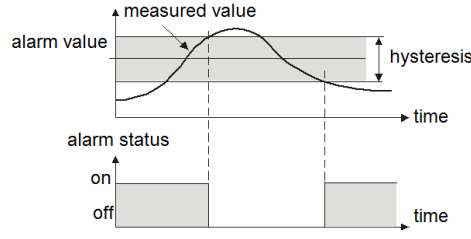
Parameter	Range of variability of the parameter and description		Company settings
Assigned inputs	numbers of the measurement channels associated with specific alarms		1÷2 or <i>None</i>
Alarm type	Off	constantly switched off alarm output	<i>Off</i>
	Reverse/heating	 <p>Fig. 12.4.1. Characteristics of a <i>Heating</i> type alarm</p>	

	Direct/cooling	<p>Fig. 12.4.2. Characteristics of a <i>Cooling</i> type alarm</p>	
	In the band	<p>Fig. 12.4.3. Characteristics of an <i>In the band</i> alarm</p>	
	Outside of the band	<p>Fig. 12.4.4. Characteristics of an <i>Outside of the band</i> alarm</p>	
Alarm value	$-199.9 \div 1,999.9 \text{ } ^\circ\text{C}$ or $-9,999 \div 19,999$ units (1)		$100.0 \text{ } ^\circ\text{C}$
Hysteresis	$0 \div 500.0 \text{ } ^\circ\text{C}$ or $0 \div 5,000$ units (1)		$0.0 \text{ } ^\circ\text{C}$

Notes: (1) - applies to analog inputs (mA, V, mV, Ω)

12.5. DISPLAY OPTIONS

Table 12.5. Configuration parameters in the *Display options* menu

Parameter	Range of variability of the parameter and description	Company settings
Time of background illumination	$0 \div 60$ min., increase by 1 min., for the 0 value the illumination is on all the time, the time is counted from the last use of the keypad	0 min. (continuous)
Brightness mode	Common for all	background brightness common for all data presentation modes (list, single measurement, configuration menu), in accordance with the Common background brightness parameter
	Separate for inputs	background brightness set separately for each channel in the single measurement display mode (chapter 12.3); in other modes, in accordance with the Common background brightness
Common background brightness	$0 \div 100$ %, change by 5%	100%

Contrast	0 ÷ 100 % , change by 5%							50 %		
Time of automatic change of the channel	0 ÷ 60 s , change every 2 s, for the 0 value, the automatic change is off, the time of automatic change of the channel in the single measurement presentation mode							0 s		
Type of diagram (chapter 11.6)	Regular		Diagram drawn with a line					Filled		
	Filled		diagram filled below the line (2-D bar graph)							
Diagram time range	100 s	300 s	15 min.	30 min.	60 min.	150min	5 h	10 h	25 h	100 s

12.6. SERIAL COMMUNICATION OPTIONS RS485, USB, AND EtherNet

The available interfaces enable communication with the computer and, consequently, the readout of the measured value and configuration of the parameters and the names, as well as access to the archive files (with the exception of the RS485). Moreover, the Ethernet (optional) enables displaying information on the operating status and on measurements of the recorder in any web browser (Opera, IE, Firefox, etc.) via the local network or the Internet. The Internet connection requires a permanent global IP number and router (modem) configuration. **The selection of the TIP and UDP port number used by the recorder and the forwarding of this port in the router should be performed by a qualified person (the network administrator).** Moreover, make sure that the firewall does not blocked the ports and applications (ARSOFT-WZ1 and WZ3) that are being used.

Table 12.6. Configuration parameters in the *Communication options* menu

Parameter	Range of variability of the parameter and description				Company settings
USB mode of operation	Available for the computer	in order to establish communication with the computer, drivers must be installed (chapter 9); the USB connection is indicated in the lower status bar (chapter 11.1)			Available for the computer
	USB memory support	the presence of the memory is indicated in the status bar (chapters 8 and 11.1)			
Speed for the RS485	2,400 bit/s	4,800 bit/s	9,600 bit/s	19,200 bit/s	19,200 bit/s
	38,400 bit/s	57,600 bit/s	115,200 bit/s		
MODBUS-RTU address	1 ÷ 247	individual address of the device in the RS485 network (chapter 18)			1
EtherNet operation mode	Off	Ethernet constantly off (recommended when not in use)			Off
	Automatic configuration	the DHCP client is on, parameters IP address , Subnet mask , and Default gateway are set automatically			
	Permanent configuration	the DHCP client is off, parameters IP address , Subnet mask , and Default gateway are set manually			
NetBIOS name	a unique name of the recorder in the local network; may be used instead of the IP address in order to establish a connection with a computer Edition of the name (no spaces, max. length 15 characters) is possible on the computer (via the USB port or the EtherNet and the ARSOFT-WZ1 software, or by copying of the configuration - chapter 12.2). The format of a section in the <i>AR200_nazwy.txt</i> file is the following: [EtherNet] NetBIOSName=AR200 The changed name may not be available on the network immediately (the update time depends on the configuration of the network).				AR200
UDP and TCP ports	80 ÷ 32767 (except for 137)	the port number and the individual IP address of the device for communication with the ARSOFT-WZ1 and WZ3 software and with the web browser; the syntax of			30200

IP address	0.0.0.0 ÷ 255.255.255.255	these parameters is the following: IP address (or the NetBIOS name): UDP and TCP port , e.g. 192.168.0.200:30200 or AR200:30200	192.168.0.200
Subnet mask	0.0.0.0 ÷ 255.255.255.255	IP address mask in the local network	255.255.255.0
Default gateway	0.0.0.0 ÷ 255.255.255.255	IP address of the router in the local network	192.168.0.10
DHCP server	Off On	useful for direct connection with a computer; switch off in networks with an existing DHCP server	Off
MAC physical address	a unique permanent hardware address of the EtherNet interface (factory-assigned)		

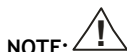

Do not connect the device in the **USB memory support** mode to the USB port of a computer as this leads to the risk of damage to the ports.

12.7. ACCESS OPTIONS

Table 12.7. Configuration parameters in the *Access options* menu

Parameter	Range of variability of the parameter and description		Company settings
Password protection	Off	entry into the <i>Main Menu</i> is not password-protected	Off
	On	entry into the <i>Main Menu</i> is password-protected	
Password	0000 ÷ 9999	password for the <i>Main Menu</i> (configuration)	1111
SD and USB authorization (1)	Off	demand of authorization of the SD card and the USB memory to save the archive is off	Off
	On	saving to an archive is possible only on an SD card or a USB memory containing the <i>AR200.2.cfg</i> configuration file with a conforming Password .	

Notes: (1) - this function prevents unintended creation of archives in the SD and USB memories put into the recorder by accident, for the purpose of off-line configuration, or by unauthorized persons. It is not recommended for recording with **Data recording interval** shorter than 3 s because it introduces an additional delay of access to the archive, thus causing uneven recording.

12.8. TIME AND DATE

Table 12.8. Configuration parameters in the *Time and date* menu

Parameter	Range of variability of the parameter
Time (hh:mm:ss)	00:00:00 ÷ 23:59:59
Date (dd:mm:yyyy)	01.06.2008 ÷ 31.12.2099

The current time and date are displayed in the status bar (chapter 11.1) in most measurement data presentation modes and are used as time stamps for recording.

In order to supply the internal clock (RTC) when the power supply is cut off, the device is fitted with a CR1220 lithium battery that suffices for at least 5 years of continuous operation.

12.9. INFORMATION ON THE DEVICE

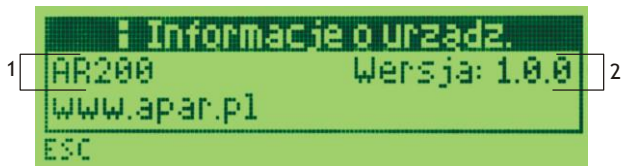

Fig. 12. Appearance of the *Information on the device* screen

Element	Description
1	type of device (AR200)
2	recorder's software (firmware) version

13. OPERATION AND FUNCTIONS OF THE SD/MMC CARD AND THE USB MEMORY (PENDRIVE)

Due to the stationary (panel) installation of the recorder, the use of SD/MMC and USB memory may be particularly suitable to transfer archived or configuration data and when the size of the internal memory is not sufficient to record the required number of measurements.

In order to access the USB memory, first make sure that the *USB operation mode* in the *Main Menu* -> *Communication Options* is set to the value of *USB memory support* (chapter 12.6); access to the SD/MMC memory does not require any programming of the configuration.

All the existing file and disk operations can be found in the *Main menu* -> *Memory and file options*, chapter 12.2. They enable, among others, copying and deleting archive files, checking the size and formatting of the selected memory.

Moreover, it is possible to select a memory to save the archive by performing configuration of parameters *Memory to save* (chapter 12.2) and *SD and USB authorization* (chapter 12.7).

An SD/MMC or USB memory that is correctly installed in the socket has the following functions:

- storage of files with saved data in the course of recording
- off-line configuration of the device's parameters (from configuration files *AR200.2.cfg* and *AR200_nazwy.txt*, see chapter 12, item 3)
- copying of archive files with the “csv” extension from the internal memory or the SD/MMC card (this action is performed from the *Memory and file options* level, see chapter 12.2).

14. VIEWING RECORDED MEASUREMENTS AND EVENTS

In order to archive data, the recorder creates text files with the “csv” extension in the internal memory, the SD/MMC memory, or the USB memory. The file name contains the device type (AR200), the identification number (ID) (chapter 12.2), and the date and time of creation of the file, e.g. “AR200_1_2009-01-09_10-57-16.csv”.

The format of a single data record is the following:

“subsequent number of the event;date;time;identifier of the event;argument1;...;argument n;checksum”.

An example record for measurement of 2 channels:

“30;2009-01-09;16:34:58;5;49,5;1020;8BE2” (measured values: “49,5;1020”).

The types and the identifiers of the recorded events are:

- measurement (identifier of event 5)
- connection to the USB port (0, “USB;CONNECTED”)

- disconnection from the USB port (1, "USB;DISCONN")
- loading of a new configuration (identifier of event 3), values of arguments:
 - "NEW;ON-LINE" - parameter configuration via the USB port, the RS485 port, or the EtherNet (on-line)
 - "NEW;OFF-LINE" - parameter configuration by way of modification of the *AR200.2.cfg* file (off-line)
 - "NEW;USER" - parameter configuration from the keypad (user) level
 - "NEW;CH_TEXT" - name configuration by way of modification of the *AR200_nazwy.txt* file
- creation of a new "csv" file (4, "ID;xxxx", where xxxx - value of the *Identification number ID* parameter of the device, chapter 12.2, Table 12.2)

In order to make a graphic or text presentation and to print the recorded results, one must import the data into the ARSOFT-WZ3 software via the USB, from the SD card, or using the EtherNet interface (the slowest of the possible methods - due to the long import time, it is not recommended in the case of large files, 10 MB and more). The ARSOFT-WZ3 software also enables detecting unauthorized modifications of the archive. As an alternative, "csv" files can be edited in spreadsheet software (OpenOffice Calc, Microsoft Excel - in the case of large files, in Excel2007), as well as in text editors (Windows WordPad, Notepad++).

NOTE: 

If the SD/MMC or USB memory is installed or removed in the course of recording, a new "csv" file is created where the subsequent numbers of events are continued from the previous file.

15. MESSAGE AND ERROR SIGNALING

The measurement errors present in the field of the measured values in all presentation modes:

- HI-- - the value set by the **Top of the indication range** is exceeded from the top (chapter 12.3), the measurement range of the sensor is exceeded from the top or the sensor is damaged
- LO-- - the value set by the **Bottom of the indication range** is exceeded from the bottom (chapter 12.3), the measurement range of a sensor is exceeded from the bottom or the sensor is damaged

Also, the recorder has a clear way of informing of its operating status and the status of the file or disk operations being performed. The message window appearing on the display must be approved with the [SET] button.



Fig. 15. Appearance of an example message window.

16. IMPORTANT COMMENTS PERTAINING TO OPERATION

In order to ensure problem-free and optimum operation of the recorder, please observe the following guidelines:

- do not disconnect the device from the computer in the course of communication via the USB interface, which is indicated with the [R/W] icon and in the ARSOFT-WZ1 software. USB communication is present when mass memory is supported (internal memory or the SD/MMC card) and during operation of the ARSOFT-WZ1 software.
- delete unnecessary files from the internal memory, the SD, and the USB memory before new recording starts

- save copies of the current configuration files (*AR200.2.cfg* and *AR200_nazwy.txt*) in external memory (SD/MMC, USB, hard drives, etc.)
- **do not allow power supply loss during data saving** as this leads to the risk of errors in the FAT file system and, consequently, to problems with recording data and loss of the current recorder configuration and reverting to the default configuration. If this happens, perform the following actions from the level of the **Main Menu** of the device or the computer connected via the USB:
 1. copy the existing archive files to an external memory (SD, USB or the computer's disk)
 2. format the internal memory
 3. configure the recorder (manually, on-line, or off-line by restoring the configuration file copies if they have been made by the user)
- do not establish communication with the device via EtherNet simultaneously from many ARSOFT-WZ1/WZ3 applications

17. RS485 COMMUNICATION INTERFACE (acc. to EIA RS-485)

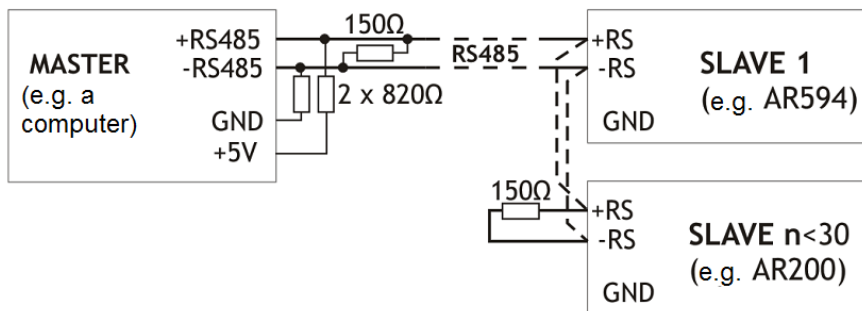

Maximum RS485 cable length - 1 km.

Maximum number of devices in a RS485 line - 30, in order to increase the number, use RS485/RS485 amplifiers.

Termination resistors when the MASTER is at the start of the line (see the figure above):

- at the start of the line - 2 x 820 Ω to the ground and +5 V of the MASTER and 150Ω between lines,
- at the end of the line - 150 Ω between lines.

Termination resistors when the MASTER is in the center of the line:

- at the converter - 2 x 820 Ω, to the ground and +5 V of the converter,
- at both ends of the line - 150 Ω each between lines.

18. MODBUS-RTU SERIAL TRANSMISSION PROTOCOL (SLAVE)

Character format : 8 bits, 1 stop bit, no parity bit

Available functions : READ - 3 or 4, WRITE - 6

Table 18.1. Claim frame format for the READ function (frame length - 8 bytes):

address of the device	function 4 or 3	read register address: 0 ÷ 85 (0x0055)	number of registers to be read: 1 ÷ 86 (0x0056)	CRC check sum
1 byte	1 byte	2 bytes (HB-LB)	2 bytes (HB-LB)	2 bytes (LB-HB)

Example 18.1. Reading of a register with address 0: 0x01 - 0x04 - 0x0000 - 0x0001 - 0x31CA

Table 18.2. Claim frame format for the WRITE function (frame length - 8 bytes):

address of the device	function 6	write register address: 0 ÷ 85 (0x0055)	write register value	CRC check sum
1 byte	1 byte	2 bytes (HB-LB)	2 bytes (HB-LB)	2 bytes (LB-HB)

Example 18.2. Entry in a register with address 10 (0xA) with the 0 value: 0x01 - 0x06 - 0x000A - 0x0000 - 0xA9C8

Table 18.3. Response frame format for the READ function (minimum frame length - 7 bytes):

address of the device	function 4 or 3	number of bytes in the data field (max. 86*2=172 bytes)	data field - register value	CRC check sum
1 byte	1 byte	1 byte	2 ÷ 172 bytes (HB-LB)	2 bytes (LB-HB)

Example 18.3. Response frame for register value equal to 0: 0x01 - 0x04 - 0x02 - 0x0000 - 0xB930

Table 18.4. Response frame format for the WRITE function (frame length - 8 bytes):

copy of the claim frame for the WRITE function (Table 18.2)

Table 18.5. Special answer (errors: function field = 0x84 or 0x83 in the case of the READ function and 0x86 in the case of the WRITE function):

Error code (HB-LB in the data field)	Error description
0x0001	non-existing register address
0x0002	wrong write register value
0x0003	improper function number

Example 18.5. Error frame for a non-existing read register address:

0x01 - 0x84 - 0x02 - 0x0001 - 0x5130

Table 18.6. Map of registers for the MODBUS-RTU protocol

Register address HEX (DEC)	Range of variability or value (HEX or DEC)	Description of register and access type (R- read only register, R/W - read and write register)	
0x00 (0)	0	not used	R
0x01 (1)	200	device type identifier	R
0x02 (2)	100 ÷ 999	recorder's software (firmware) version	R
0x03 (3)	-100 ÷ 700	internal device temperature (resolution 0.1 °C)	R
0x04 (4)	0 ÷ 3	current status of outputs 1, 2: bits 0, 1, bit=1 means that the output is on; applies to firmware version 1.1.9 and higher	R

0x05 ÷ 0x0B	0	not used or reserved	R	
0x0C ÷ 0x0D	-9999 ÷ 19999	measurement value (channel1-channel2)	R	
0x0E ÷ 0x13	0	not used	R	
0x14 (20)	0 ÷ 6	day of the week in the internal RTC clock (counted based on the date)	R	
0x15 (21)	0x0101 ÷ 0x630C	years (HB) and months (LB)	Internal real time clock (RTC, chapter 12.8)	R/W
0x16 (22)	0x0100 ÷ 0x1F17	days (HB) and hours (LB)		R/W
0x17 (23)	0x0000 ÷ 0x3B3B	minutes (HB) and seconds (LB)		R/W
0x18 (24)	0x0101 ÷ 0x630C	years (HB) and months (LB)	Parameter <i>Start of the time limit</i> (chapter 12.1)	R/W
0x19 (25)	0x0100 ÷ 0x1F17	days (HB) and hours (LB)		R/W
0x1A (26)	0x0000 ÷ 0x3B3B	minutes (HB) and seconds (LB)		R/W
0x1B (27)	0x0101 ÷ 0x630C	years (HB) and months (LB)	Parameter <i>End of the time limit</i> (chapter 12.1)	R/W
0x1C (28)	0x0100 ÷ 0x1F17	days (HB) and hours (LB)		R/W
0x1D (29)	0x0000 ÷ 0x3B3B	minutes (HB) and seconds (LB)		R/W
0x1E (30)	1 ÷ 28800	Parameter <i>Data recording interval</i> (chapter 12.1) - number of seconds	R/W	
0x1F (31)	0 ÷ 4	Parameter <i>Type of recording</i> (chapter 12.1)	R/W	
0x20 (32)	0 ÷ 1	Parameter <i>Selection of permission channel</i> (chapter 12.1)	R/W	
0x21 (33)	-9999 ÷ 19999	Parameter <i>Permission threshold value</i> (chapter 12.1)	R/W	
0x22 (34)	0 ÷ 2	Parameter <i>Storage memory</i> (chapter 12.2)	R/W	
Configuration parameters for the measurement channel numbered KP = 0 ÷ 1 (0=channel 1, 1=channel 2)				
0x23 + KP*11	0 ÷ 15	Parameter <i>Type of input</i> (chapter 12.3)	R/W	
0x24 + KP*11	0 ÷ 5000	Parameter <i>Line resistance</i> (chapter 12.3)	R/W	
0x25 + KP*11	0 ÷ 600	Parameter <i>Thermocouple cold tip temperature</i> (chap. 12.3)	R/W	
0x26 + KP*11	0 ÷ 4	Parameter <i>Position of the point/resolution</i> (chapter 12.3)	R/W	
0x27 + KP*11	-9999 ÷ 19999	Parameter <i>Bottom of the indication range</i> (chapter 12.3)	R/W	
0x28 + KP*11	-9999 ÷ 19999	Parameter <i>Top of the indication range</i> (chapter 12.3)	R/W	
0x29 + KP*11	0 ÷ 10	Parameter <i>Filtration</i> (chapter 12.3)	R/W	
0x2A + KP*11	-500 ÷ 500	Parameter <i>Zero calibration</i> (chapter 12.3)	R/W	
0x2B + KP*11	850 ÷ 1150	Parameter <i>Inclination calibration</i> (chapter 12.3)	R/W	
0x2C + KP*11	0 ÷ 3	Parameter <i>Assignment of outputs</i> (chapter 12.3)	R/W	
0x2D + KP*11	0 ÷ 100	Parameter <i>Background brightness</i> (chapter 12.3)	R/W	
Configuration parameters of an alarm channel numbered KA = 0 ÷ 1 (0-channel 1, 1-channel 2)				
0x39 + KA*3	0 ÷ 4	Parameter <i>Type of alarm</i> (chapter 12.4)	R/W	
0x3A + KA*3	0 ÷ 5000	Parameter <i>Hysteresis</i> (chapter 12.4)	R/W	
0x3B + KA*3	-9999 ÷ 19999	Parameter <i>Alarm value</i> (chapter 12.4)	R/W	
0x3F (63)	0 ÷ 1	Parameter <i>Password protection</i> (chapter 12.7)	R/W	
0x40 (64)	0 ÷ 9999	Parameter <i>Password</i> (chapter 12.7)	R/W	
0x41 (65)	0 ÷ 1	Parameter <i>SD and USB authorization</i> (chapter 12.7)	R/W	
0x42 (66)	0 ÷ 9999	Parameter <i>Identification number ID</i> (chapter 12.2)	R/W	
0x43 (67)	0 ÷ 60	Parameter <i>Background illumination time</i> (chapter 12.5)	R/W	
0x44 (68)	0 ÷ 1	Parameter <i>Brightness mode</i> (chapter 12.5)	R/W	
0x45 (69)	0 ÷ 100	Parameter <i>Common background brightness</i> (chapter 12.5)	R/W	
0x46 (70)	6 ÷ 24	Parameter <i>Contrast</i> (chapter 12.5)	R/W	
0x47 (71)	0 ÷ 60	Parameter <i>Time of automatic channel change</i> (chapter 12.5)	R/W	
0x48 (72)	0 ÷ 1	Parameter <i>Type of diagram</i> (chapter 12.5)	R/W	

0x49 (73)	0 ÷ 8	Parameter <i>Diagram time range</i> (chapter 12.5)	R/W	
0x4A (74)	0 ÷ 1	Parameter <i>USB operation mode</i> (chapter 12.6)	R/W	
0x4B (75)	1 ÷ 247	Parameter <i>MODBUS-RTU address</i> (chapter 12.6)	R/W	
0x4C (76)	0 ÷ 6	Parameter <i>Speed for the RS485</i> (chapter 12.6)	R/W	
0x4D (77)	0 ÷ 2	Parameter Ethernet operation mode (chapter 12.6)	R/W	
0x4E (78)	80 ÷ 32767	Parameter UDP and TCP ports (except for the value 137, chapter 12.6)	R/W	
0x4F (79)	0x0000 ÷ 0xFFFF	Octet4 (HB) and Octet3 (LB)	Parameter <i>IP address</i> (chapter 12.6)	R/W
0x50 (80)	0x0000 ÷ 0xFFFF	Octet2 (HB) and Octet1 (LB)		R/W
0x51 (81)	0x0000 ÷ 0xFFFF	Octet4 (HB) and Octet3 (LB)	Parameter <i>Subnet mask</i> (chapter 12.6)	R/W
0x52 (82)	0x0000 ÷ 0xFFFF	Octet2 (HB) and Octet1 (LB)		R/W
0x53 (83)	0x0000 ÷ 0xFFFF	Octet4 (HB) and Octet3 (LB)	Parameter <i>Default gate</i> (chapter 12.6)	R/W
0x54 (84)	0x0000 ÷ 0xFFFF	Octet2 (HB) and Octet1 (LB)		R/W
0x55 (85)	0 ÷ 1	Parameter <i>DHCP server</i> (chapter 12.6)	R/W	

19. USER'S NOTES
